

DC Brush Motor & Gear

12 or 24VDC Brush Motor

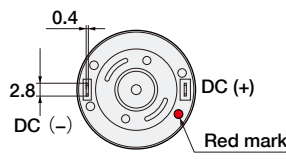
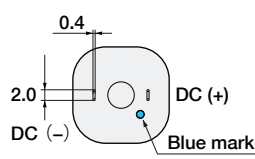

■ **Motor wiring and terminal dimensions diagrams**

■ **Cutting hole dimensions**

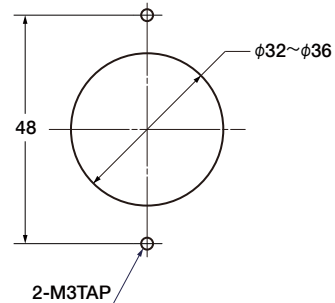

WPM□ - □AA - □P

WPM□ - □BA - □P

12 or 24VDC Brush Motor

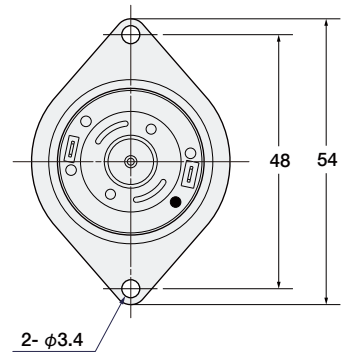
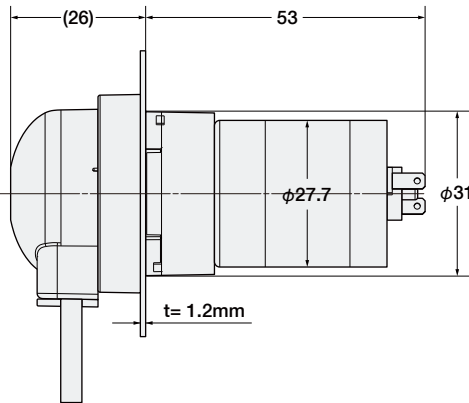
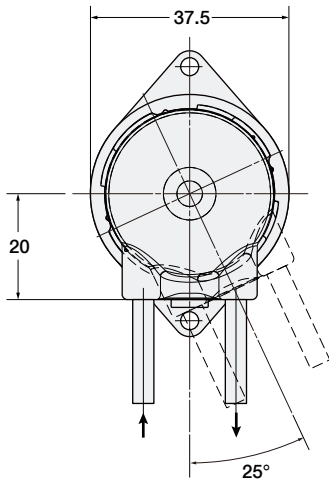

Weight: 83g

WPM□ - □CA - □P

12VDC Compact Brush Motor

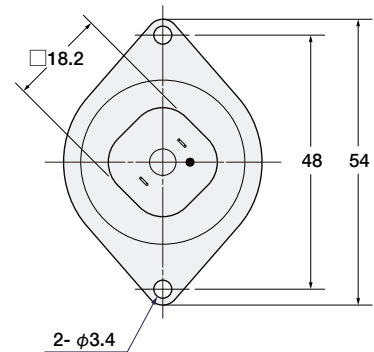
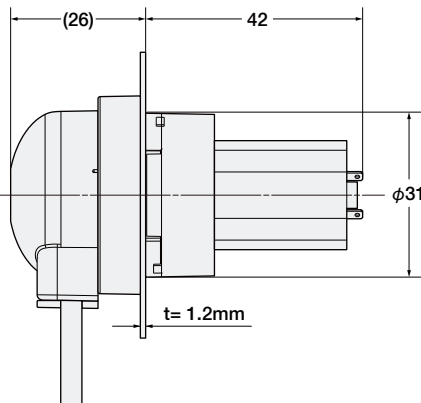
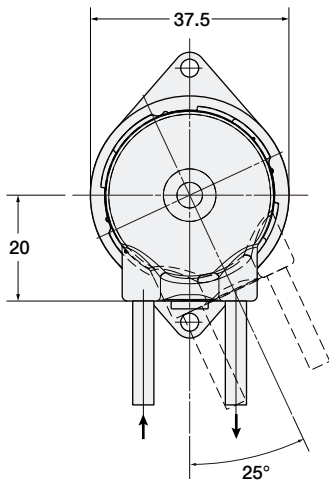

Weight: 67g